



# OWNER'S MANUAL

## *FULL DC INVERTER XPOWER VRF OUTDOOR UNIT*

Thank you for purchasing this air conditioner.  
Before using it, please read this manual and keep it for future reference.

---

**Caution:** The heating function of an indoor unit is available only when it is connected to a cooling & heating outdoor unit.

---



**CONTENTS**

**PAGE**

IMPORTANT SAFETY INFORMATION.....	1
PART NAMES.....	2
OPERATION AND PERFORMANCE.....	2
FAULTS AND CAUSES.....	3
MALFUNCTIONS.....	5
CONSTRAINT COOLING AND QUERIES.....	6
AFTER-SALES SERVICE.....	6
CUSTOMER DETAILS.....	7

# 1. IMPORTANT SAFETY INFORMATION

To prevent injury or property damage from mis-operations, follow these instructions.

There are two types of safety precautions - please read both carefully.



## WARNING

Failure to observe a warning may result in serious injury or death. The appliance must be installed in accordance with national wiring regulations.



## CAUTION

Failure to observe a caution may result in injury or damage to the equipment.



## WARNING

- **Ask your dealer about installing the air conditioner.**  
If you install the unit incorrectly yourself, you risk water leaks, electric shock, and fires.
- **Ask your dealer for information about upgrades, repairs, and maintenance.**  
If you perform these yourself, you risk water leaks, electric shock, and fires
- **To avoid electric shocks, fires, and injury, power the unit off and contact your dealer if the unit becomes faulty**
- **Never replace a blown fuse with another that has a different current rating.**  
Using wire or copper wire may cause the unit to break down or cause a fire.
- **Do not insert your fingers or any object into the air inlet or outlet.**  
When the fan is rotating at high speed, it can cause injury.
- **Never use flammable sprays such as hair spray, lacquers, or paint near the unit because doing so may result in a fire.**
- **Never touch the air outlet or horizontal blades while the swing flap is in use because your fingers may become trapped or you might damage the unit.**
- **The appliance must be installed in accordance with national wiring regulations**

- **Never inspect or service the unit yourself.**  
Ask a professional for help.
- **Do not dispose this product as unsorted waste. It must be separately collected and processed.**
- **Do not dispose of electrical appliances as unsorted waste. They must be separately collected and processed.**  
Contact your local government for details.
- **If electrical appliances are disposed of in landfills or dumps, hazardous substances can leak into the groundwater and thus enter the food chain.**
- **Keep the unit away from high-frequency equipment.**
- **Keep the unit away from the following places to avoid damage:**  
Gaseous areas (e.g., hot springs, which release sulfides), coastal areas (except corrosion-resistant models).
- **Prevent air from flowing backwards into the outdoor unit in strong winds.**
- **Snow canopies are necessary for outdoor unit in snowy areas. Consult your local dealer for details.**
- **Lightning-proof the unit if you live in a stormy area.**
- **For information about refrigerant leaks, contact your dealer.**  
When the system is installed in a small room, keep the refrigerant below the limit; otherwise, if there's a leak, the oxygen in the room may be affected, causing a serious accident.
- **The refrigerant in the unit is safe and should not leak.**  
If it does and comes into contact with fire, a harmful gas will result.
- **Turn off any combustible heating devices, ventilate the room, and contact the dealer you purchased the unit from.**  
Do not use the unit until a technician instructs you that it's safe to do so.



## CAUTION

- **The cooling & heating indoor unit can be connected to a cooling & heating outdoor unit or a cooling-only outdoor unit; the heating function of the indoor unit is available only when it is connected to a cooling & heating outdoor unit.**
- **Only use the air conditioner for its prescribed purpose.**  
This air conditioner is not designed for cooling in spaces accommodating precision instruments, food, plants, animals, or artworks.

- **Power the unit off before cleaning it to avoid electric shocks.**
- **Install an earth leak detector to avoid electric shocks and fires.**
- **Ensure the air conditioner is grounded.**  
To avoid electric shocks, ensure the unit is grounded and that the earth wire is not connected to a gas or water pipe, lightning conductor, or telephone earth wire.
- **To avoid injury, do not remove the fan guard of the outdoor unit.**
- **Do not touch the unit with wet hands** because you may get an electric shock.
- **Do not touch the heat exchanger fins because you may receive serious cuts.**
- **After a long use, check the unit stand and fitting for damage.**  
If damaged, the unit may fall.
- **To avoid oxygen deficiency, ventilate the room sufficiently if equipment with a burner is used at the same time as the air conditioner.**
- **Arrange the drainage hose to ensure smooth drainage.**  
Incomplete drainage may cause water leaks.
- **Never expose children, plants or animals directly to the air flow.**
- **Avoid places that amplify the noise or create noise pollution for others.**
- **Noise can be amplified by anything that blocks the air outlet of the outdoor unit.**
- **Choose a place to dissipate noise and hot or cold air from the outdoor unit that doesn't affect others or harm animals or plants.**
- **Do not allow a child to mount on the outdoor unit and don't place objects on it.**
- **Do not run the air conditioner when fumigating a room with insecticide as chemicals could get in the unit, causing respiratory problems for people affected.**
- **Do not place appliances that produce open fire in places in the path of the air flow from the unit or under the indoor unit due to the risk of combustion or warping.**
- **To avoid fire, do not install the air conditioner where flammable gas may leak from.**
- **Children and the elderly should not operate the unit.**
- **Children should not play with the unit. Don't leave young children unsupervised.**

## 2. PARTS NAMES

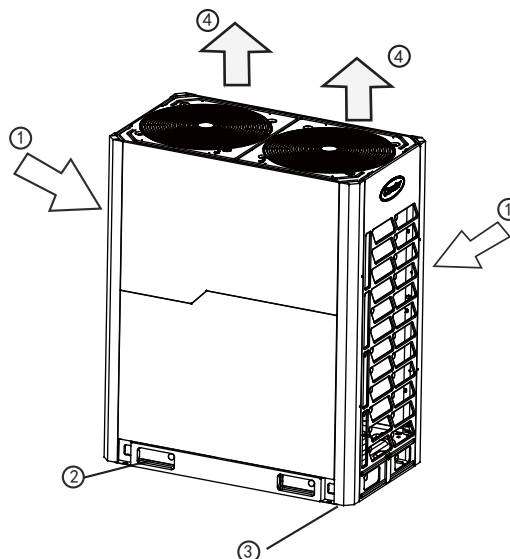

Fig.2-1

The figure shown above is for reference only, and the actual product may be different.

①	Air inlet (on the left and right sides, and at the rear. )
②	Refrigerant pipe connective opening and wires outlet
③	Fixed foot
④	Air outlet (heats air to be blown out for cooling and vice versa)



### NOTE

- Diagrams in this manual are for illustration purpose only. The appearance and functions described here may differ from the model you've purchased. Please refer to the actual product.
- Don't insert any object into the unit.
- Preheat the unit for at least 12 hours before use. Do not power the unit off if you won't be using it for less than 24 hours. (This is to heat the crank case heater so as to prevent the compressor from starting with liquid.)
- Make sure the air inlet and outlet are not blocked, or it may degrade the performance of air conditioner or activate the protector which will stop the unit from running.

## 3. OPERATION AND PERFORMANCE

### ■ Cooling and heating operation of inverter central DC

- The indoor unit can be controlled on its own. It cannot cool and heat at the same time.
- For any problems with the cooling and heating modes, find the problem via the settings of the outdoor unit's dial code S5.
  1. If you set the unit to Heating Priority mode, the indoor unit running in Cooling or Fan mode stops, the operation panel displays Non-priority or Standby, but the indoor unit running in Heating mode will run continuously.
  2. If you set the unit to Cooling Priority mode, the indoor unit running in Heating or Fan mode stops, the operation panel displays Non-priority or Standby, but the indoor unit running in Cooling mode will run continuously.
  3. If you set the unit to No. 63 (VIP indoor unit) + Voting Priority mode, and set and start the No. 63 indoor unit, the operation mode of the No. 63 unit will be the priority operation mode of the system. If you do not set or start the No. 63 indoor unit, the mode used by a majority of indoor units will be the priority operation mode of the system.

4. If you set the unit to only respond to the Heating mode, the indoor unit will run normally if it is running in Heating mode, but it will display Mode Conflict if it is running in Cooling or Fan mode.

5. If you set the unit to only respond to the Cooling mode, the indoor unit will run normally if it is running in Cooling or Fan mode, but it will display Mode Conflict if it is running in Heating mode.

■ **Features of Heating mode**

- It takes 3 to 5 minutes for the unit to blow out hot air.
- The fan motor in the outdoor unit may stop running under high temperatures.
- If other indoor units are running in Heating mode, the fan may stop to prevent expelling hot air.

■ **Defrost in Heating mode**

- In Heating mode, the outdoor unit sometimes frost. To increase efficiency, the unit will start defrosting automatically (for about 2-10 minutes), and then water will drain out from outdoor unit.
- During defrosting, both the fan motors in the outdoor unit and indoor unit will stop running.

■ **Operation conditions**

For normal performance, run the air conditioner under the following temperature conditions:

Table.3-1

Temperature Mode	Outdoor temperature	Indoor temperature	Room relative humidity
Cooling mode	-5°C ~ 48°C	17°C ~ 32°C	below 80%
Heating mode (Cooling only type without)	-20°C ~ 24°C	≤27°C	



**NOTE**

Protection measures may activate and stop the unit running outside of the above conditions.

■ **Protection Device**

This protection device will stop the unit automatically if the air conditioner is on forced running mode. When the protection device is activated, the running indicator will light up and the query light will flash. Protection device may start under the following circumstances:

■ cooling operation:

- The air inlet or air outlet of outdoor unit is blocked.
- Strong wind continuously blows from the air outlet of the outdoor unit.

■ Heating operation:

- Too much dust is trapped in the dust filter in the indoor unit

■ **Power cut**

- Power the unit off if there's a power cut.
- When power resumes, the indicator on the wire controller flashes.
- Push the ON/OFF button again to restart the unit.

**Mis-operation**

In case of a mis-operation caused by lightning or mobile wireless device, switch off the power manually. Push ON/OFF again to restart.

**Heating capacity**

- • The heating process is to absorb heat from outdoors and expel heat indoors by the hot pump. Once the outdoor temperature drops, heating capacity degrades correspondingly.
- Use other heating appliances when the outdoor temperature is low.
- (See Indoor Unit Operation Manual for detailed information)



**NOTE**

Power the unit off when the protection device starts. Do not restart until the problems are solved.

**4. TROUBLES AND CAUSES**



**CAUTION**

- Power of the unit and contact your dealer if the following malfunctions occur. Incorrect ON/OFF operation
- Fuse or leakage protector breaks.
- Foreign matter or water enters in the unit.

	Troubles	Causes
<b>Not a malfunction</b>	<b>Outdoor unit</b> <ul style="list-style-type: none"> <li>Mist or water</li> <li>The unit hisses</li> </ul>	<ul style="list-style-type: none"> <li>FAN function stop automatically to defrost is accompanied by the starting and stopping sound of the solenoid valve.</li> <li>At the beginning and end of the running process, it sounds like water is flowing in the valve for 3-15 minutes due to the dehumidifying process of the refrigerant current.</li> <li>A slight hiss is caused by heat exchanger as temperature changes.</li> <li>Various foreign matter gets into the unit.</li> <li>Switch on the power after a power cut.</li> <li>The preheating processes of other equipment stops the cooling operation.</li> <li>The user sets a mode that conflicts with the fixed cooling and heating mode.</li> <li>FAN mode stops to avoid expelling cold air.</li> </ul>
	<b>Indoor unit</b> <ul style="list-style-type: none"> <li>Bad odor</li> <li>Operation light flashes</li> <li>No priority or Standby on the panel lights up</li> </ul>	
<b>Check it again</b>	<ul style="list-style-type: none"> <li>Starts or stops operation automatically</li> </ul>	<ul style="list-style-type: none"> <li>Mis-operation of the timer.</li> </ul>
	<ul style="list-style-type: none"> <li>Will not run</li> </ul>	<ul style="list-style-type: none"> <li>Whether the power is cut.</li> <li>Whether the manual power switch is turned on.</li> <li>Whether the fuse has melted.</li> <li>Whether the protection device works (operation light is on)</li> <li>Whether it is the time set.</li> </ul>
	<ul style="list-style-type: none"> <li>Insufficient cooling</li> <li>Insufficient heating</li> </ul>	<ul style="list-style-type: none"> <li>Whether the inlet and outlet of outdoor unit is blocked.</li> <li>Whether the door and window are open.</li> <li>Whether the air filter is blocked by dust.</li> <li>Whether the air deflector is in the right place</li> <li>Whether the fan speed is slight or whether it is in FAN mode.</li> <li>Whether the temperature is set properly.</li> <li>Setting COOL and HEAT simultaneously (indicator light for Standby or No Priority on the panel is on)</li> </ul>

## 5. MALFUNCTION

Malfunction display of outdoor unit's DSP1

Table.5-1

No.	Error code	Error or protection type	Note
1	E0	Outdoor unit COMM.Error	Only display in slave unit
2	E1	Phase protection	
3	E2	COMM.Error with indoor unit	Twenty minutes after the first power on or indoor and outdoor communication break off after 2 minutes when the unit has been running for 20 minutes
4	E3	Reserve	
5	E4	Outdoor temp. sensor error	
6	E5	Voltage protection	
7	E6	Reserve	
8	E7	Discharge temp.sensor error	
9	E8	Outdoor unit address error	
10	xE9	Mismatching the drive model	X represents for a system, 1 is A system, 2 is B system
11	xH0	COMM. Error between IR341 and main chip	
12	H1	COMM. Error between 0537 and main chip	
13	H2	Qty.of outdoor unit decreases error	Only main unit will display
14	H3	Qty.of outdoor unit increases error	Only main unit will display
15	xH4	unrecoverable module protection outage(P6)	X represents for a system, 1 is A system, 2 is B system, not recoverable until re-power on
16	H5	Three times the P2 protection in 60 minutes	Not recoverable until re-power on
17	H6	Three times the P4 protection in 100 minutes	Not recoverable until re-power on
18	H7	Qty.of indoor units decreases error	Indoor unit lost for over 3 minutes; not recoverable, until the unit qty. recovers
19	H8	High-pressure sensor error	Air discharging pressure $P_c \leq 0.3\text{MPa}$
20	H9	Three times the P9 protection in 60 minutes	Not recoverable until re-power on
21	Hc	Reserve	
22	F0	Three times the PP protection in 150 minutes	Not recoverable until re-power on
23	C7	Three times the PL protection in 100 minutes	Not recoverable until re-power on
24	yHd	Auxiliary unit error (y=1,2, 3.e.g,1Hd stands for auxiliary unit1 error)	Y represents a unit which is not No. 0
25	P0	Inverter compressor top Temp.protection	
26	P1	High-pressure protection	
27	P2	Low-pressure protection	Reports H5 after P2 protection is activated three times 60 minutes
28	xP3	Compressor current protection	X represents for a system, 1 is A system, 2 is B system
29	P4	Discharge Temp.Protection	Reports H6 after P6 protection is activated three times 100 minutes
30	P5	High condenser Temp.protection	
31	xP6	Inverter module protection	X represents for a system, 1 is A system, 2 is B system; reports H4 if P6 protection is activated three times 60 minutes
32	P9	DC fan protection	Reports H9 if P9 protection is activated three times in 60 minutes
33	PL	Inverter module Temp.sensor error	Reports C7 if PL protection is activated in 100 minutes.
34	PP	Protection at an insufficient degree against superheating compressor discharge	Reports F0 if PP protection is activated in 150 minutes
35	xL0	DC compressor module error	X represents the system, 1 is A system, 2 is B system
36	xL1	DC bus low-pressure protection	X represents the system, 1 is A system, 2 is B system
37	xL2	DC bus high-pressure protection	X represents the system, 1 is A system, 2 is B system
38	xL3	Reserve	X represents the system, 1 is A system, 2 is B system
39	xL4	MCE error/synchronization/closed loop	X represents the system, 1 is A system, 2 is B system
40	xL5	Zero-speed protection	X represents the system, 1 is A system, 2 is B system
41	xL6	Reserve	X represents the system, 1 is A system, 2 is B system
42	xL7	Phase-error protection	X represents the system, 1 is A system, 2 is B system
43	xL8	Protection of the speed change between a moment before and after is $> 15\text{Hz}$	X represents the system, 1 is A system, 2 is B system
44	xL9	Protection of the speed change between the setting speed and the actual speed $> 15\text{Hz}$	X represents the system, 1 is A system, 2 is B system

If the problem still exists, please contact the sales distributor or the service center, tell us your model No. and the detail of the error.

## 6. CONSTRAINT COOLING AND QUERY

### ■ Constraint Cooling

Once pressing the constraint cooling button (see the chart on the right), all indoor units will be on forced cooling mode and the wind speed is HIGH).

### ■ Usage application of the SW2 spot check

Table.6-1

No.	Display content (normal display)	Note
1	Outdoor unit address	0, 1, 2, 3
2	Outdoor unit itself capacity	8, 10, 12, 14, 16, 18, 20, 22
3	Modular outdoor unit qty.	Available for main unit
4	Qty.setting of indoor units	Available for main unit
5	Total capacity of outdoor units	Capacity requirement
6	Total requirement of indoor unit capacity	Available for main unit
7	Total requirement of main unit corrected capacity	Available for main unit
8	Operation mode	0, 2, 3, 4
9	This outdoor unit actual operation capacity	Capacity requirement
10	Speed of fan A	
11	Speed of fan B	
12	T2B/T2 average temp.	Actual value
13	T3 pipe temp.	Actual value
14	T4 ambient temp.	Actual value
15	Discharge Temp.of Inverter compressor A	Actual value
16	Discharge Temp.of Inverter compressor B	Actual value
17	Heat sink Temp.	Actual value
18	Discharge pressure corresponding to the saturation temperature	Actual value +30
19	Current of inverter compressor A	Actual value
20	Current of inverter compressor B	Actual value
21	Opening angle of EXV A	
22	Opening angle of EXV B	
23	High pressure	Display value×0.1MPa
24	Low pressure (reserve)	
25	Qty. of Indoor units	that can communicate with indoor units
26	Qty. of working indoor units	Actual value
27	Priority mode	0, 1, 2, 3, 4
28	Night noise control mode	0, 1, 2, 3
29	Static pressure mode	0, 1, 2, 3
30	DC voltage A	
31	DC voltage B	
32	Reserve	
33	Last-time error or protection code	If there is no protection or error, the panel displays 8.8.8.
34	Times errors cleared	
35	-----	Check end

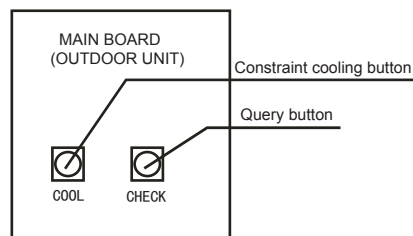

Fig.6-1

The display contents as followings:

(1) Normal display: When standby, the high position displays the address of the outdoor unit, and the low position displays the Qty. of indoor units that can communicate with outdoor unit. When it's on, it will display the rotation frequency of the compressor.

(2) Operation mode: 0-OFF; 2-Cooling; 3-Heating; 4-Constraint cooling.

(3) Fan speed: 0-stop; 1~15: speed increase sequentially, 15 is the max. fan speed.

(4) EXV opening angle: Pulse count=display value×8.

(5) Priority mode: 0-heating priority mode; 1-cooling priority mode; 2-Number 63 & the more operating mode first; 3-respond the heating mode only; 4-respond the cooling mode only.

(6) Night noise control mode:0-Night noise control mode; 1- silent mode ; 2-most silent mode;3-no priority.

(7) Static pressure mode:0-Static pressure is 0 Mpa; 1-Static pressure mode is low pressure; 2-Static pressure mode is medium pressure; 3-high static pressure mode is high pressure.

## 7. AFTER-SALE SERVICE

If the air conditioner is operating abnormally, please unplug it at the mains and contact the after-sales center or special distributor. For details, please refer to the attached accessory Consumer Service Instructions.



## 8. CUSTOMER DETAILS

Branch Address : .....

.....

.....

Telephone : .....

Person to be contacted : .....

Dealer address : .....

.....

.....

Telephone : .....

Person to be contacted : .....

.....

Signature of the Dealer with Seal.

In all correspondence/communication state your name, address, the serial number of your air conditioning unit, date of purchase and dealer's name (include address), location of unit and description of problem, for prompt and immediate attention

Name of Customer : .....

Address : .....

.....

.....

Sr.No. of the Unit : .....

Sr.No. of the Compressor : ..... Date of purchase:.....

Invoice No : .....

# CE



此页不做印刷，仅做变更说明：

A升级到B：更改第2页操作和性能描述中，A/C改为DC，SW2改为S5；  
更改说明书的第5页表5-1的第21、22、33、34行内容；  
更改说明书的第18页点检附加说明中模式优先的说明内容，由原来的先开优先，改为63号机和多开优先。

B升级到C：更改第三页表3-1的制热温度范围。

C升级到D：第三页增加面板仅供参考描述。

C升级到D：整本说明书内容翻译校正，内容不变。